

PRODUCT DATA SHEET



PROBATONE 5

Type of system:	Shop roaster (batch capacity of 5 kg)
Kind of system:	Drum roaster
Field of application:	Roasted coffee

THE ESSENTIAL ADVANTAGES OF THE PROBATONE 5 AT A GLANCE:

- Homogeneous roasting of the coffee with Probat-specific product-air ratio and special shovel mechanism
- Quick, gentle cooling of the roasted coffee by a large cooling sieve and even distribution with food-safe plastic scrapers
- Cleaning brush underneath the cooling sieve removes bean particles and chaff
- Classic, nostalgic design by many components made of high-quality cast iron
- Reduced cycle time by simultaneous roasting and cooling with separate ventilators
- Efficient drive concept by separate motors for drum drive, cooling sieve stirring arm, as well as, roaster and cooler fan
- Greater flexibility during roasting by adjustable gas regulation
- Efficient heating by proven burner technology
- Simplified cleaning by removable side walls
- Separate roasting cyclone for an effective chaff separation
- Accurate operation with digital time and temperature display
- Hand-crank for emptying the roasting drum in the event of a power outage. Alternatively, a supplied adapter makes it possible to attach a cordless screwdriver to simplify discharging.



PRODUCT DATA SHEET

PROBATONE 5



DESCRIPTION OF OPERATION:

With its classic, nostalgic design, the PROBATONE 5 serves for batch-by-batch production of high-quality coffee. An excellent roasting quality as well as a planable, efficient roasting result are surely the pre-conditions for a successful coffee roaster. The Probatone 5 is the perfect partner, among other things, due to the possibility of producing replicable, consistent roasting results.

A batch of green coffee, max. 5 kg, is weighed and placed into the filling hopper (B1). When the temperature has reached approx. 210°C, the slide gate (B2), is opened and the coffee is filled into the roasting drum. After filling, the slide gate has to be closed.

The roasting process is monitored by viewing the coffee through the sight glass and taking samples with the sampler. The burner (D1), located underneath the roasting drum, can be increased and decreased depending on desired degree of roast and roasting time. The product temperature is measured continuously and displayed digitally on the operating panel.

An even heat transfer, as well as, a very gentle and efficient mixing of the coffee is achieved by the special shovel mechanism in the roasting drum.

The cooling of the coffee is carried out by the cooling ventilator (V1) which draws ambient air (X3) through the roasted product and sieve. In doing so,

the roasting product is efficiently cooled.

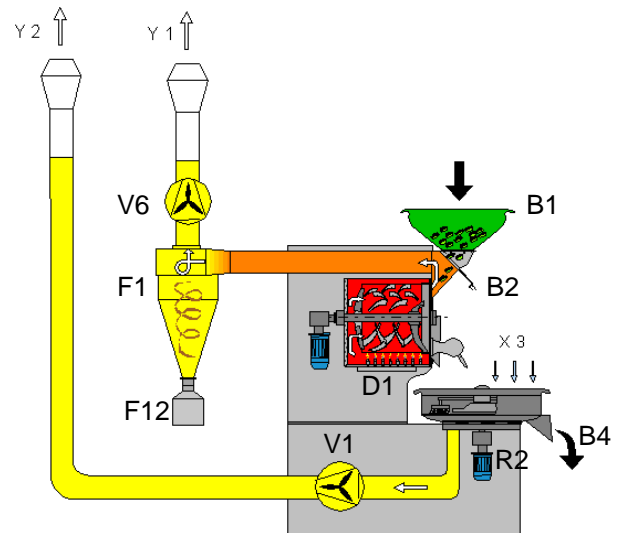

The stirring mechanism (R2) serves to evenly distribute the coffee and to simplify the emptying.

After the coffee has been cooled, it is emptied via the discharge door (B4) into a provided bin. During the cooling cycle, a further batch can be filled and roasted once the desired filling temperature has been reached.

The exhaust gases and chaff created during roasting are transported via the roaster fan (V6) to the roasting cyclone (F1). Here, the chaff and dust is separated from the roasting air by means of centrifugal force and gravity. A chaff collecting bin (F12) arranged under the roasting cyclone collects the chaff.

The roasting (Y1) and cooling (Y2) air is released into the open via the chimney.

PRODUCT DATA SHEET



PROBATONE 5

DIMENSIONS AND WEIGHT OF THE ROASTER

Dimensions in mm approx.	l	1,470
	b	878
	h	1,856
Filling hopper in mm approx.	Ø d ₁	425
Cooling sieve in mm approx.	Ø d ₂	659
Cooling sieve emptying in mm approx.	h ₂	783
Roasting exhaust air duct in mm approx.	Ø d ₃	NW 60
	h ₃	1,650
Cooling exhaust air duct in mm approx.	Ø d ₄	NW 100
	h ₄	370
Gas connection in mm approx.	h ₅	35
Operating weight in kg approx.	Roaster	340

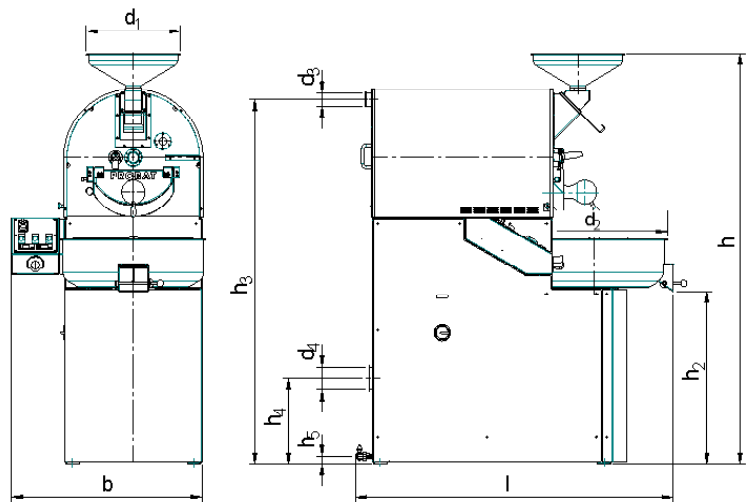

DIMENSIONS AND WEIGHT OF THE ROASTING CYCLONE

Dimensions in mm approx.	l	450
	b	300
	h	2,054
Roasting exhaust air duct in mm approx.	Ø d ₆	NW 80
	h ₆	1,650
Exhaust air duct in mm approx.	Ø d ₇	NW 80
	h ₇	1,838
Operating weight in kg approx.	Cyclone	44

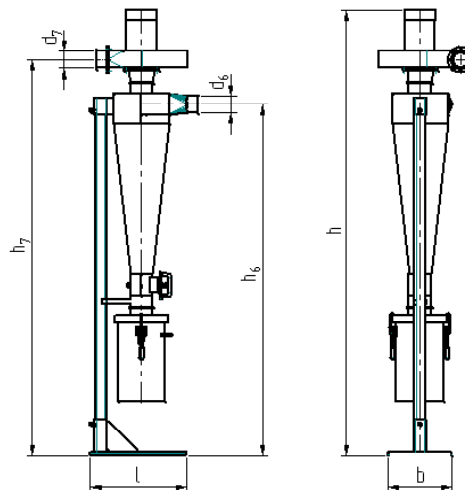

PRODUCT DATA SHEET



PROBATONE 5

CONNECTING AND CONSUMPTION DATA

Voltage supply	
Supply voltage (three-phase current)	400 V or 230 V
	50 Hz or 60 Hz

Current consumption	
PROBATONE 5	< 0.3 kWh/5kg

Nominal power	
Drum drive	0.12 kW
Stirring mechanism drive	0.09 kW
Roaster fan	0.22 kW / 0.30 kW
Cooler fan	0.22 kW / 0.30 kW

Kind of gas	Nozzle designation	Gas pressure	Nominal gas power
Natural gas	120	20 mbar	50 MJ/h
Propane	75	50 mbar	

Kind of gas	Calorific value H_u	Gas consumption during nominal power
Natural gas	10.3 kWh/Nm ³	1.3 m ³ /h
Propane	25.8 kWh/Nm ³	0.5 m ³ /h

Exhaust air volume flow	
Roasting	100 m ³ /h norm
Cooling	250 m ³ /h norm